



Pollution
& Process
Monitoring

LABTOC

LABORATORY TOC WATER ANALYSIS SYSTEM



Laboratory TOC Water Analy

LABTOC

LABTOC is a fast, reliable and highly accurate system for the laboratory analysis of sample water.

Simple to use, LABTOC can be used by laboratory technicians with the minimum of training and still be relied upon to produce precisely accurate TOC and/or TC values from single or multiple samples with a range from 0-10 ppm to 0-4000 ppm.

LABTOC consists of an organics analyser, based on proven PPM PROTOC chemical technology, an auto-sampler capable of feeding between one and eighty eight separate samples to the analyser during a single run, and an IBM-compatible PC with exclusive, user-friendly software, which both controls the analytical process and monitors the results.

Competitively priced and highly flexible, LABTOC is ideal for applications where multiple samples need to be taken from a variety of areas or variable areas on a single site, or from a number of sampling points on multiple sites for further analysis.



PPM THE TOC SPECIALISTS

As such, it is suitable for use by industry or by regulating authorities charged with monitoring widely divergent areas such as points along a river.

LABTOC will also be of interest to companies offering off-site sample analysis service to industry, water authorities in sewage receiving applications and environmental companies engaged in waste analysis and disposal contracts.

Increasingly, the Total Organic Carbon (TOC) content found in water streams is regarded as an excellent indication of water quality, and many protocols now specify TOC or TC analysis.

TOC testing can also compliment existing BOD or COD testing facilities, particularly if organics are of major importance in the analysis exercise.

LABTOC systems can be custom-designed and built to customer's own specifications and software customised as required to meet more specialised requirements.

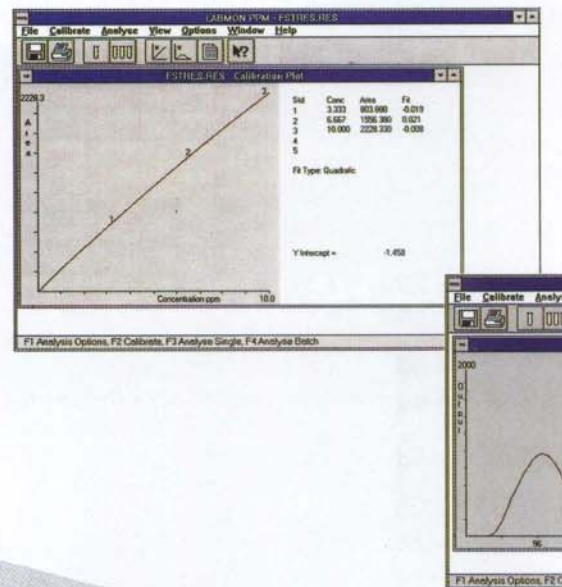

FEATURES

- User friendly Windows-driven software
- Provides TOC and/or TC analysis
- Full on-screen and hard copy reporting
- Range from 10 ppm to 4,000 ppm, fully adjustable
- Multi-point calibration with 'Best Fit' curves
- Print calc curve (with results)
- Fully automatic QC diagnostic
- Automatic re-calibration on QC failure
- Multiple runs on each sample with SD, RSD and mean value
- Automatic range adjustment for over ranging samples
- Single and batch analysis (no syringe required)
- Automatic shut off after batch analysis
- No manual acidification of sample

is System

PRINCIPLE OF OPERATION

The sample is continuously drawn in through the autosampler dip probe. This is then joined by a continuous flow of acidified reactor fluid which - depending on the mode of operation - is either TC pumped directly to the injection valve, or TOC routed via an IC removal stage to the injection valve.

Once the fresh sample has had time to flush out the injection valve it is switched by the PC for a precisely determined amount of time, diverting the flow of sample momentarily into the flow of fresh reagent which is being pumped constantly into the reactor.

The organic carbon contained in the sample is then converted to CO_2 by the UV light and the sodium persulphate. This is carried by a very constant flow of gas, firstly to a Gas Liquid Separator (GLS). The gas is finally dried by passing through a permeation dryer tube.

CO_2 concentration is then measured by a solid state infrared detector which is tuned only for the detection of CO_2 . The output of the infrared is then fed back directly into the PC where the signal is measured and integrated to provide a precise measurement of TOC or TC, as required.

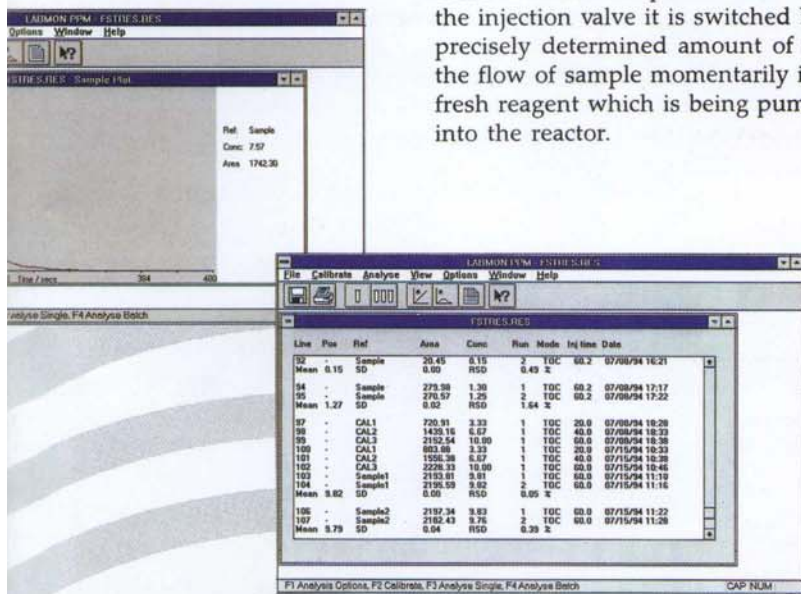

OTHER SYSTEMS FROM PPM

- PROTOC - Continuous on-line process organics analyser (TOC)
- PROTOC 100 - Low cost, on-line TOC water monitor
- PROTOC 2000 - Auto ranging on-line TOC monitoring system

Please ask for further information.

CONTROL AND MONITORING OPTIONS

The LABTOC analyser and auto-sampler units are controlled by an IBM - compatible PC. Data produced by the analyser is sent to the PC in turn, where it can be displayed graphically and automatically stored on floppy disk for later retrieval or as a permanent record of sample data.

The PC features PPM's own exclusive Labmon™

Windows-driven software, providing a user friendly, clear and flexible means of controlling sampling and presenting sample data.

This data can then be displayed graphically and, if required, a hard copy can be made on a colour graphics printer.

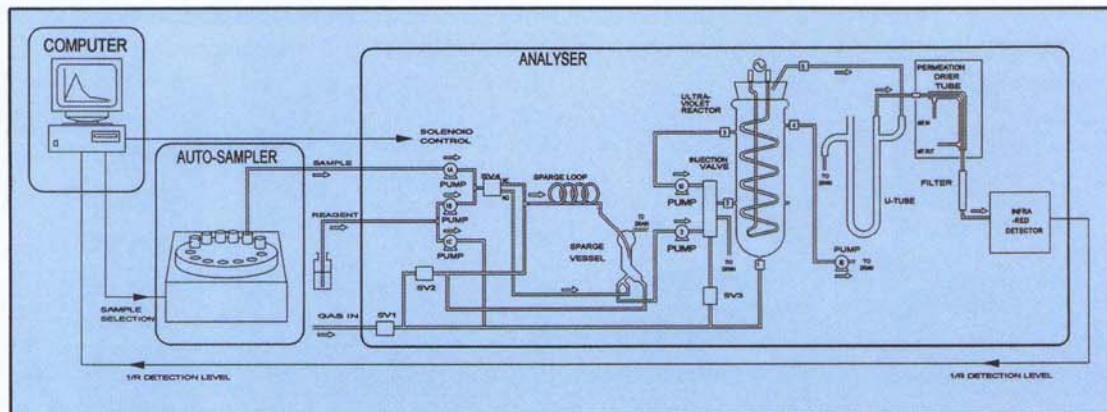

CUSTOMER SERVICE

PPM are specialists in water pollution monitoring instrumentation and can offer a choice of quality on-site, on line and laboratory-based TC/TOC monitoring. Systems can be custom designed and built to meet individual company and industrial requirements. Software may also be customised to order.

The company also offers a full installation and

customer familiarisation package as well as an optional, comprehensive maintenance programme.

Pollution & Process Monitoring Ltd is committed to a policy of continuous research and development. The right is therefore reserved to change specifications without notice in the interest of ongoing product development.

Specifications

<i>Analysis Modes:</i>	TC, TOC, TC and TOC
<i>Sample Modes:</i>	Single sample Batch of up to 48/88 samples
<i>Repeat Samplings:</i>	From 1 to 3 runs (selectable)
<i>Calibration:</i>	Manual calibration, with choice of calibration curve Automatic calibration at start of batch QC calibration at selectable intervals during batch
<i>Range:</i>	Variable between 0-10 ppm to 0-4000 ppm
<i>Detection limit:</i>	1% of calibrated range
<i>Linearity:</i>	Better than 1% of calibrated range
<i>Repeatability:</i>	Within 2%
<i>Analysis time:</i>	Typically 6 minutes per sample
<i>Data Handling:</i>	By PC (manual supplied)
<i>Records:</i>	Results which are written to file and may be printed include calibration plots and tabular sample data. (On screen plot of measured concentration during run is not maintained)
<i>Warm up time:</i>	20 minutes from power on or stand-by
<i>Analyser Output:</i>	4-20 mA
<i>Sampler Prep Time:</i>	120 seconds
<i>A/D Base Address:</i>	380 Seconds

POWER	Voltage	Frequency
Analysers:	240V ac	50Hz
	110V ac	60Hz
Auto-Sampler:	240V ac	50Hz
	110V ac	60Hz

EXTERNAL DIMENSIONS

<i>Analysers:</i>	550mm H x 300mm W x 550mm D
<i>Weight (approx):</i>	25kg
<i>Auto-sampler:</i>	560mm H x 660mm W x 710mm D
<i>Weight:</i>	22kg

UTILITIES REQUIRED

<i>Gas:</i>	Nitrogen/Oxygen/Argon clean gas, ie. dust and oil free to be supplied @ 60 psi constant
<i>Typical usage:</i>	TC 180 ml/min TOC 560 ml/min

REAGENT

5% sodium persulphate, 5% orthophosphoric acid in DI water
Typical consumption is 1 ml/min

OPTIONS

<i>IC Analysis:</i>	Allowing TOC by difference TC - IC = TOC
<i>Low Level IR:</i>	Permitting an analysis range of 0-100 ppb up to 0-40 ppm



Pollution
& Process
Monitoring

Pollution & Process
Monitoring Limited
Bourne Enterprise Centre
Borough Green,
Sevenoaks
Kent TN15 8DG England
Tel: +44 (0)1732 882044
Fax: +44 (0)1732 780190



Agent